

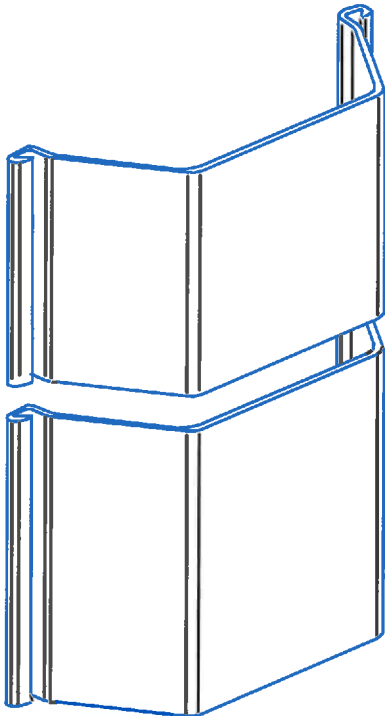

Butt welding sheet piles
Soudage bout à bout palplanches
Stumpfstoß von Spundbohlen

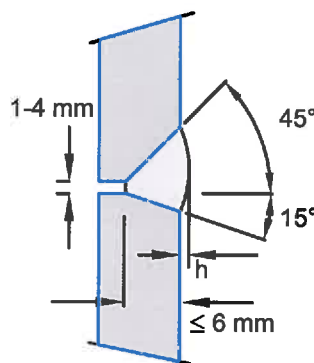

View / Vue / Ansicht
A - A



View / Vue / Ansicht
B - B

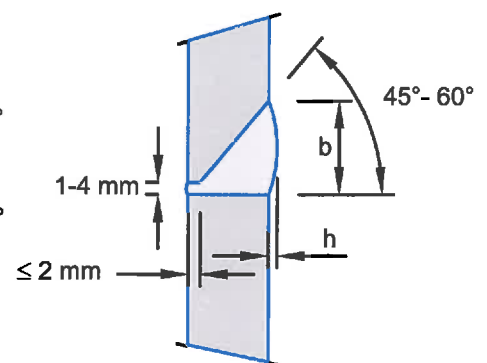

$h \leq 1 \text{ mm} + 0.25 b$

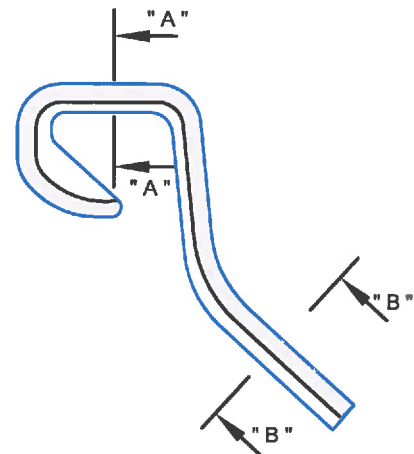

Weld material must not get inside of interlock.
Le métal déposé ne doit en aucun cas rentrer à l'intérieur du joint.
Das Schweissgut darf nicht in die Schlosskammer eindringen.

Weld shall be grinded outside of the interlock
Le cordon de soudure est à meuler sur la face extérieure du joint.
Die Schweissnaht um das Schloss ist glatt und eben zu verputzen.

Welding procedure specification acc. to ; Descriptif de mode opératoire de soudage svt. ; Schweissanweisung gemäss ; EN ISO 15609-1	Welders qualified according to ; Soudeurs agréés svt ; Schweisser qualifiziert nach ; EN 287-1 / EN 1418	Welding quality according to ; Exécution des soudures svt. ; Schweissnahtgüte ; EN ISO 5817 " D "
Welding procedure qualification acc. to ; Epreuve de qualification d'un mode opératoire de soudage svt. ; Schweissverfahrensprüfung gemäss ; EN ISO 15614-1	Requirements for welding supervisory staff ; Coordination en soudage ; Anforderung an das Schweissaufsichtspersonal ; EN 14731	



Butt welding sheet piles
Soudage bout à bout palplanches
Stumpfstoß von Spundbohlen

U

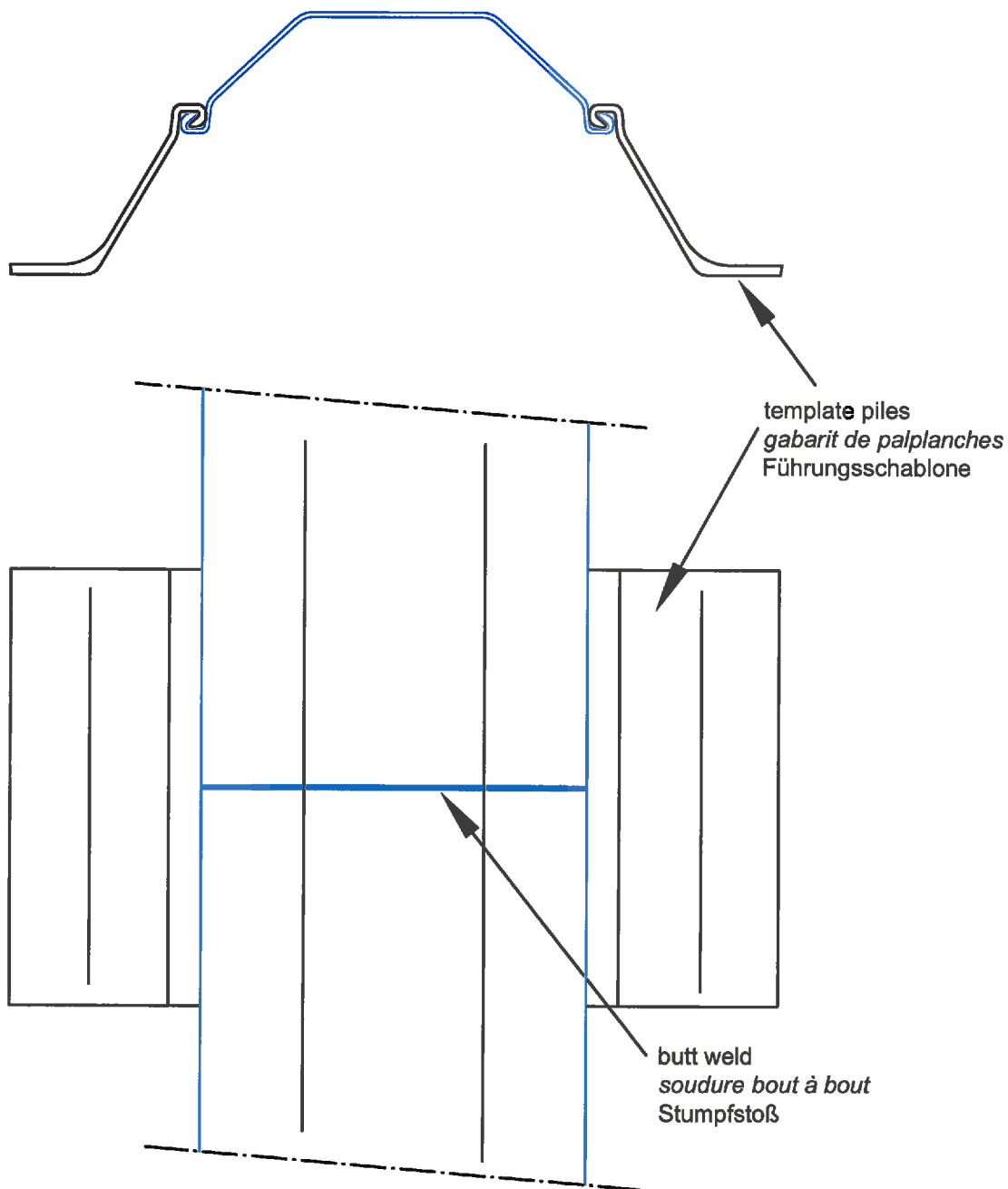



Butt welding sheet piles
Soudage bout à bout palplanches
Stumpfstoß von Spundbohlen

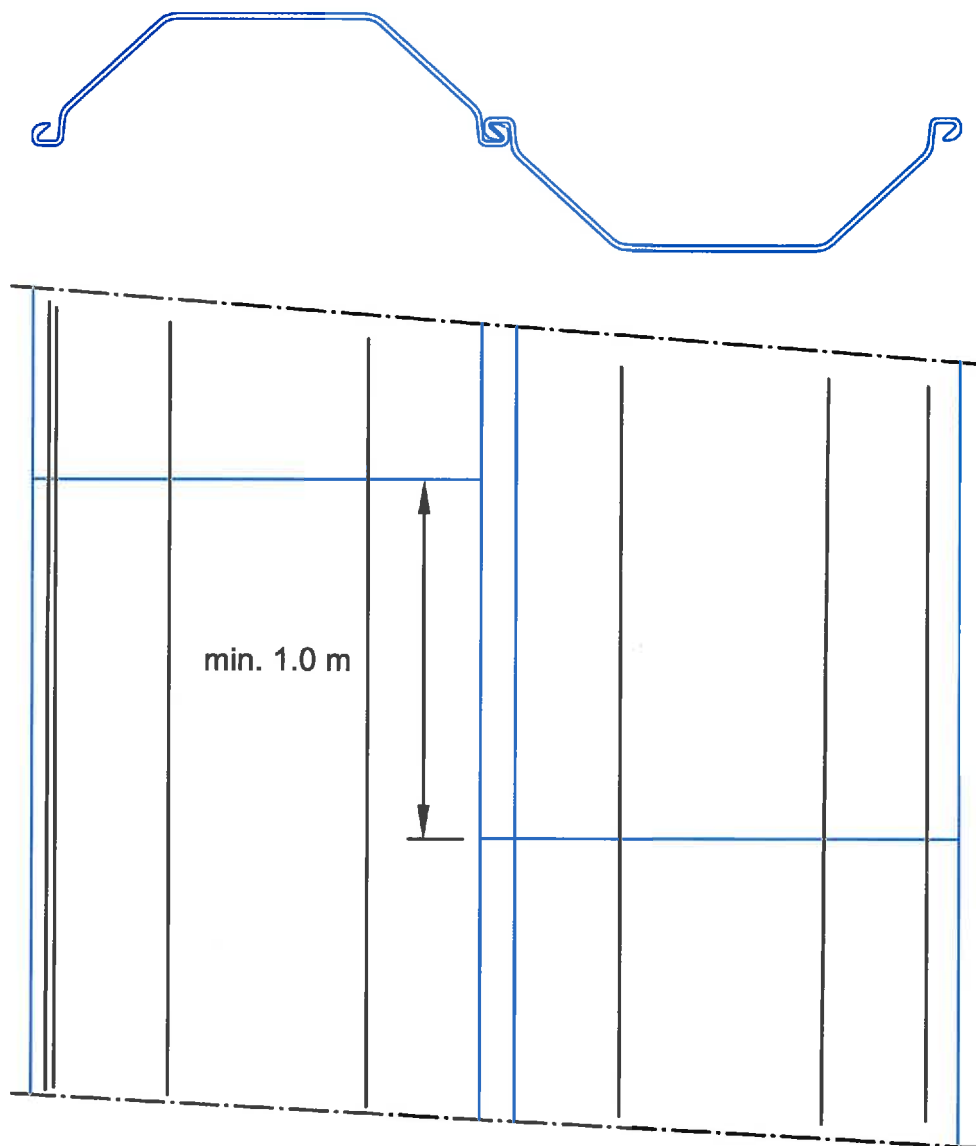

Splicing levels staggered by about 1.0 m
Niveau de raboutage décaler d'au moins 1.0 m
Lage der Stumpfstöße um mindestens 1.0 m verstetzt.



Splicing of sheet piles using plates
Entures de palplanches au moyen de plaques de recouvrement
Verbindungsstoß von Spundbohle mittels Laschen

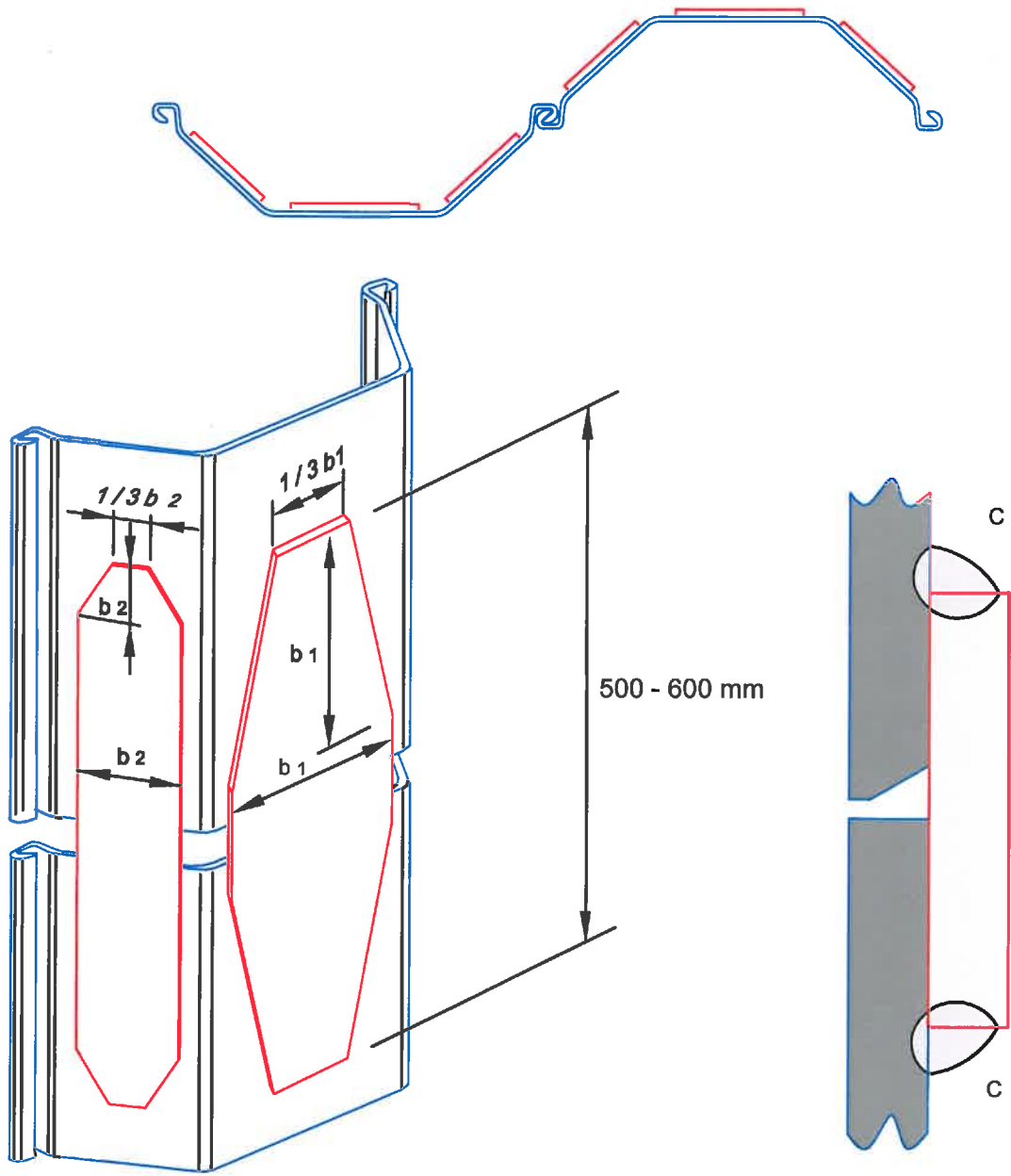

C) continuous weld / soudure continue / Durchgehende Schweissnaht : $a_{eff} \geq 7 \text{ mm}$

Welding procedure specification acc. to ; Descriptif de mode opératoire de soudage svt. ; Schweissanweisung gemäss ; EN ISO 15609-1	Welders qualified according to ; Soudeurs agréés svt ; Schweisser qualifiziert nach ; EN 287-1 / EN 1418	Welding quality according to ; Exécution des soudures svt. ; Schweissnahtgüte ; EN ISO 5817 " D "
	Requirements for welding supervisory staff ; Coordination en soudage ; Anforderung an das Schweissaufsichtspersonal ; EN 14731	

ArcelorMittal Commercial RPS S.à r.l.
Sheet Piling

66, rue de Luxembourg
L - 4221 Esch-sur-Alzette (Luxembourg)

Phone : (+352) 5313 - 3105
Fax : (+352) 5313 - 3290
E-mail : sheetpiling@arcelormittal.com
Web site : www.arcelormittal.com/sheetpiling

043 / d